

RAY Series

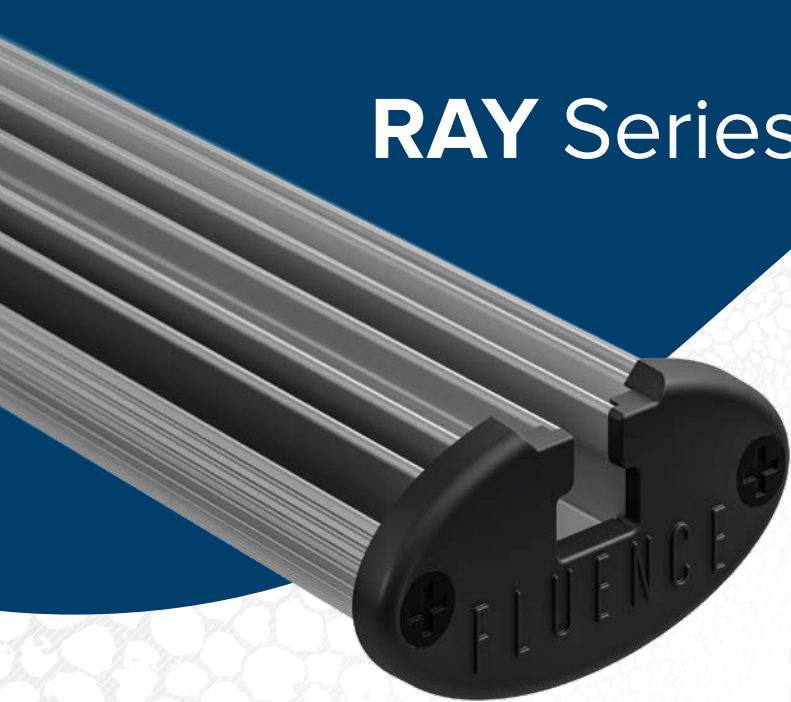

RAY 22
RAY 44
RAY 66

USER MANUAL

IMPORTANT SAFETY PRECAUTIONS & EXPLANATION OF SYMBOLS	2
BEST PRACTICES	3
GENERAL CARE	4
SYSTEM HARDWARE & ACCESSORIES	6
ASSEMBLY INSTRUCTIONS	7
TECHNICAL SPECIFICATIONS	8
CAUTIONS & WARNINGS	11
PRODUCT GUARANTEE & WARRANTY	12



IMPORTANT SAFETY PRECAUTIONS AND EXPLANATION OF SYMBOLS

- Please read this manual thoroughly before attempting to install or operate any Fluence RAY Series system.
- After successful installation and configuration of the system, be sure to retain this manual in a safe place for future reference. Safety is a key component to a long lasting and trouble free installation.
- It is important you read, fully understand, and observe the subsequent safety precautions. If you are not comfortable with the installation of high performance lighting systems, you should seek the services of a qualified installation professional or call us for help.
- **NOTICE:** RAY is a high-performance lighting system. Do not touch while in operation.
- Connect the system only to the power sources of the appropriate voltage using the AC plug type received. Protect power cables from being pinched, walked on, or otherwise damaged. Be especially careful where the power cable enters the power outlet and the unit. Only connect the system to an electrical outlet or extension cord of appropriate type and rating. Connect the system only to the power sources of the correct voltage using the plug received.

- DO NOT defeat the safety purpose of a grounding or polarized plug by removing ground pins or using unsafe adapters. A polarized plug has two blades –one wider than the other. A grounding plug has a third ground prong in addition to the two main conductors. The wide blade or third grounding prong is provided for your safety. If the provided plug does not fit your outlet, consult an electrician to replace your obsolete outlet. If you replace the power cord, only use one of similar type and equal or greater current rating.
- The system should only be cleaned as directed in the manual. You should seek service for your system by qualified service personnel if any of the following occur:
 1. The power-supply cord or the plug has been damaged.
 2. The unit has been exposed to rain.
 3. The unit exhibits a marked change in performance.
 4. The unit has been dropped, or its enclosure or chassis is damaged.

BEST PRACTICES

Fluence encourages everyone to experiment and pursue their own techniques. Every crop is different and everyone has different goals. However, our internal research has given us insight into several strategies we would like to share.

- Regularly check your plants' growth and health. Fluence lighting systems deliver high levels of PAR, typically more than experienced in nature. Adjustments to H₂O, CO₂, RH, nutrients, and temperature are typically required.
- Mount the fixture at least 6" from the top of your canopy to ensure optimal uniformity and consistent PPFD. The RAY Series was designed to provide uniform light dispersion and requires precise deployment. A 1" variation in either direction will have a significant change in uniformity and PPFD (which may or may not be desired).
- Many plants prefer higher temperatures when exposed to high PPFD. Experiment with higher temperatures to achieve higher yields. Canopy temperature and room ambient temperature often vary. For accurate results, test at the canopy level to gauge leaf surface temperature.

For cultivation recommendations visit fluence.science/science-articles/

GENERAL CARE

- RAY Series systems are passively cooled with zero moving components. They are designed for harsh environments and years of maintenance-free performance. Some basic care will keep your system operating at peak performance cycle-after-cycle.
- Natural convection removes heat away from the heatsink. In order for the system to properly cool itself, at least one inch of space is required between the fixture and the surface it is mounted to. Failure to provide adequate space may shorten the fixture's lifespan.
- To achieve the optimal lifespan and performance of your fixtures, routinely check for and remove excess dust, debris, and mineral build up from heatsink and LED array. Cleaning should always be done with the fixture unplugged from its power source using low-pressure compressed air or water to rinse away dirt from light bars.
- Never use a cloth to clean the diode array. Doing so can scratch or compromise the integrity of the silicon seal, or dislodge diodes entirely.
- To limit degradation, avoid touching the diodes with your hands, even in a powered off state.

For detailed instructions for maintenance and cleaning, please visit fluence.science/support-center/

**RAY is a high-performance lighting system.
Do not touch while in operation.**

**PLEASE RECYCLE ALL
PACKAGING MATERIAL**



SYSTEM HARDWARE & ACCESSORIES

SYSTEM HARDWARE

- A** RAY fixture pre-configured with:
 - A1** 8' Cord with Male DC Connector
- B** Power Supply pre-configured with:
 - B1** 14" Cord with Male AC Connector
 - B2** 13.5" Cord with Female DC Connector
 - B3** 13.5" Cord with 3-Pin Waterproof Dimming Connector and Dust Cap (dimmer sold separately)
 - B4** Pigtail Dimming Adapter (purple/gray leads)

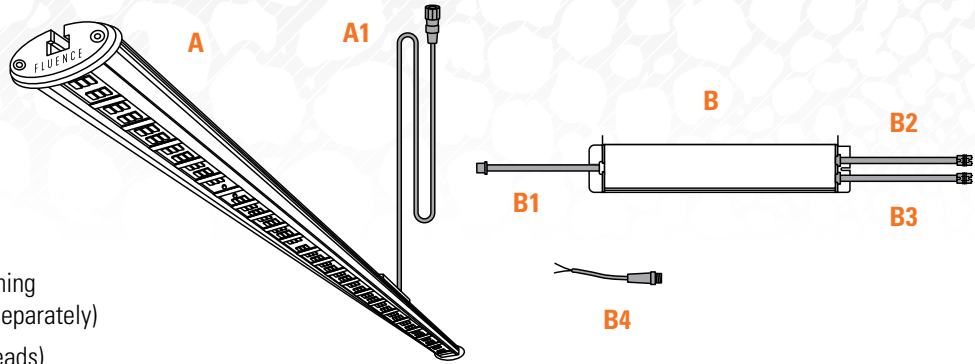

ACCESSORIES

- C** Mounting Hardware
(depending on your selection at the time of purchase)
 - C1** (2x) Standard top-light mounting brackets
 - C2** (1x) 6' AC cable
(15' cable option if upgraded at time of purchase)

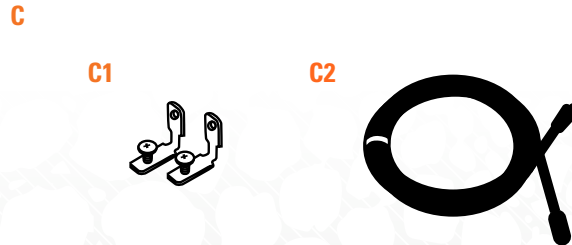

ASSEMBLY INSTRUCTIONS

- 1 Unbox RAY fixture and place on flush, stable surface.
- 2 To mount fixture, refer to the instructions included in the hanging kit package with the associated accessories. Hang the fixture in the desired location and adjust the mounting height to at least 6" above the plant canopy.
- 3 Connect fixture to power supply using the 8' DC cable attached to the RAY fixture.
- 4 Mount the power supply to a wall or suitable support structure using 4mm/#8 fasteners (not included) through the mounting flange on the sides of the power supply.
- 5 Attach 6' (or 15') AC cable to power supply AC connector. Finally, insert AC plug into wall outlet.
- 6 If connecting RAY to a dimming system or controller, remove dust cap and connect to the 3-pin waterproof dimming connector or the included pigtail dimming adapter.

Note, leave dust cap attached to connector when not dimming fixture.

Take caution when handling RAY fixtures.

Ensure the LED array does not come in contact with sharp objects or force that may damage the diodes.



TECHNICAL SPECIFICATIONS

STOCK KEEPING UNIT (SKU) CONFIGURATOR & OPTIONS

(Example SKU: R-22-I-1-06-N5-R)

Family	Model	Spectrum	Input Voltage	AC Cord Length	AC Plug	Mounting Hardware
RR RAY	2 22"	I PhysioSpec Indoor™	1 100-277V	06 6.0' (1.83m)	N5 NEMA 5–15P	R Standard
	4 44"	G PhysioSpec Greenhouse™		15 15.0' (4.57m)	N6 NEMA 6–15P	
	6 66"	A AnthoSpec™		L7 NEMA L7–15P		
		F PfrSpec™		PT Pigtails		
		R PrSpec™				
	U UvSpec™					

PHOTON FLUX AND EFFICACY Photon Flux (360-780nm) | AC Power @ 277 V | Efficacy (360-780nm) @ 277 V AC

Spectrum	RAY 22			RAY 44			RAY 66		
	Photon Flux (μmol/s)	AC Power (W)	Efficacy (μmol/J)	Photon Flux (μmol/s)	AC Power (W)	Efficacy (μmol/J)	Photon Flux (μmol/s)	AC Power (W)	Efficacy (μmol/J)
Indoor	93	40	2.33	185	79	2.34	278	115	2.42
Greenhouse	93	40	2.33	185	79	2.34	278	115	2.42
Antho	79	43	1.84	158	87	1.82	237	126	1.88
Pfr	81	32	2.53	162	65	2.49	243	94	2.59
Pr	91	37	2.46	182	74	2.46	273	108	2.53
UV	33	39	0.85	66	78	0.85	99	114	0.87

DIMENSIONS

RAY 22	1.3 lb (0.6 kg)	22" x 1.4" x 2.2" (55.9 cm x 3.6 cm x 5.6 cm)
RAY 44	2.2 lb (1.0 kg)	44" x 1.4" x 2.2" (111.8 cm x 3.6 cm x 5.6 cm)
RAY 66	3.1 lb (1.4 kg)	66" x 1.4" x 2.2" (167.6 cm x 3.6 cm x 5.6 cm)

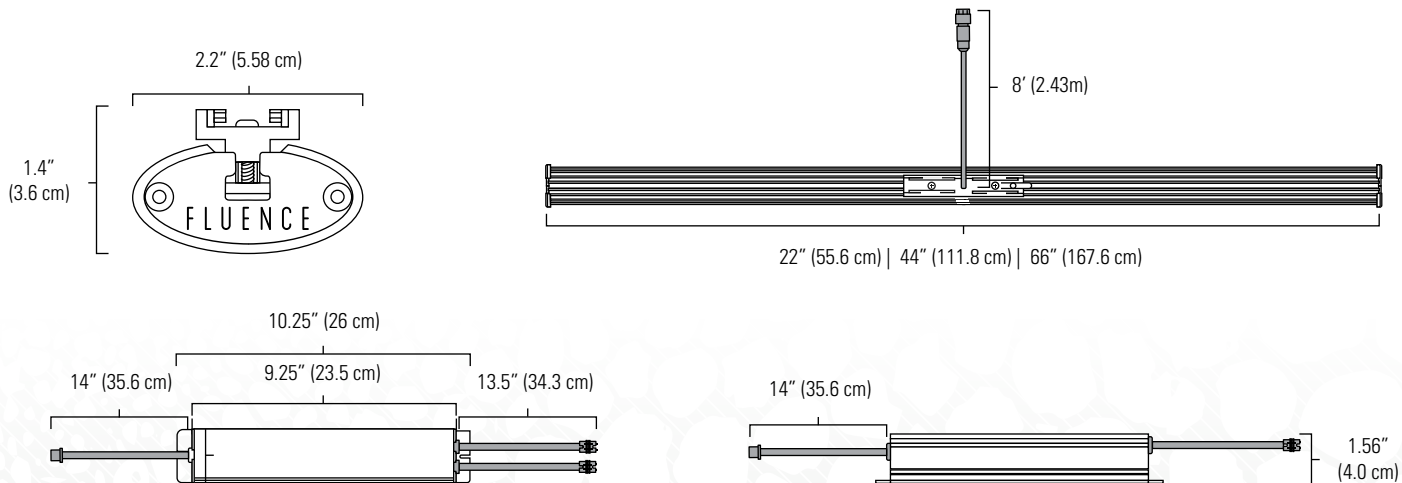

MAXIMUM AC INPUT AMPERAGE

Spectrum		AC Voltage	120 V	208 V	240 V	277 V
RAY 22	Indoor	Max AC Input Current	0.34 A	0.20 A	0.17 A	0.15 A
	Greenhouse		0.34 A	0.20 A	0.17 A	0.15 A
	Antho		0.38 A	0.22 A	0.19 A	0.17 A
	Pfr		0.28 A	0.16 A	0.14 A	0.13 A
	Pr		0.32 A	0.19 A	0.16 A	0.14 A
	UV		0.34 A	0.20 A	0.17 A	0.15 A
RAY 44	Indoor	Max AC Input Current	0.69 A	0.40 A	0.36 A	0.32 A
	Greenhouse		0.69 A	0.40 A	0.36 A	0.32 A
	Antho		0.76 A	0.45 A	0.39 A	0.36 A
	Pfr		0.57 A	0.33 A	0.30 A	0.27 A
	Pr		0.64 A	0.38 A	0.33 A	0.30 A
	UV		0.68 A	0.40 A	0.35 A	0.32 A
RAY 66	Indoor	Max AC Input Current	1.02 A	0.59 A	0.50 A	0.44 A
	Greenhouse		1.02 A	0.59 A	0.50 A	0.45 A
	Antho		1.12 A	0.65 A	0.56 A	0.49 A
	Pfr		0.84 A	0.49 A	0.42 A	0.37 A
	Pr		0.96 A	0.55 A	0.47 A	0.42 A
	UV		1.01 A	0.58 A	0.50 A	0.44A

WARNING

Risk of electrical shock. To reduce the possibility of serious injury, always take the proper precautions and unplug the fixture before moving or cleaning.

WARNING

Fixture and power supply are UL 1598 Damp Location rated and are not designed to be submerged in water. In the event that the module or power supply enclosure becomes submersed, first disengage the circuit breaker, then unplug submersed components before proceeding to remove from water.

CAUTION

To prevent eye damage, avoid looking directly at the unshielded LEDs.

CAUTION

LED and heatsink surfaces may be hot. Allow sufficient cooling time before handling.

CAUTION

To reduce the risk of overheating or fire, never place operating fixtures face down on a flush surface. Always allow for adequate ventilation of fixtures and power supplies.

CHEMICAL EXPOSURE PRECAUTION

Fluence lighting systems are designed to be resilient against crop protection products. Many chemicals used in the Commercial Horticultural Industry are corrosive to electronic equipment. Care should be taken to ensure that only approved crop protection products, cleaning agents and/or other chemicals (e.g., pesticides, fungicides and insecticides) may come in contact with the luminaire. If the luminaire is accidentally exposed to a corrosive liquid or vapor (e.g. VOC –Volatile Organic Compound and H2S – Hydrogen Sulfide) the luminaire must be rinsed with clean water as soon as possible. The product warranty will no longer apply if the product is repeatedly exposed or remains in the corrosive environment for a prolonged period. It is recommended the luminaires be removed and protected from the corrosive environment during all periods of aggressive disinfection or sanitization of the facility. The product warranty will be void if the product is repeatedly exposed to Sulfur.



ETL Rating: RAY fixtures are rated suitable for damp locations. A “damp location” is defined as an interior or exterior location in which water or other liquids may drip, splash or flow on or against the electrical components of a lighting fixture or ceiling fan. RAY22, RAY44 & RAY66 are certified to meet UL standards (ETL) from the Intertek safety consulting and certification company and are cETL listed.

1 PPF calculations compiled using integrating sphere measurements and typical spectroradiometric data for each LED to determine typical fixture performance. Actual photometric results may vary within the LED manufacturer's bin tolerance.

2 Wattage values are typical expected values. Fluence maintains a tolerance of $\pm 10\%$ on flux and power specifications. Target light levels can vary from projected levels depending on ambient temperature, room reflections values and dirt accumulation.



OUR PRODUCT GUARANTEE & WARRANTY

Every RAY series system is engineered and built by Fluence Bioengineering using state-of-the-art robotics and hand craftsmanship. RAY series systems are guaranteed against manufacturing defects for five years from date of purchase. Contact us at support@fluence-led.com for more warranty information.

We stand behind our research, we stand behind our technology and we stand behind our clients. fluence.science/warranty/



Review our products, share your grow and stay abreast of the latest Fluence news and product releases through the channels below:



fluence.science

© Copyright 2023. Fluence Bioengineering, Inc.
032023 • 70334E